

All the facts at a glance

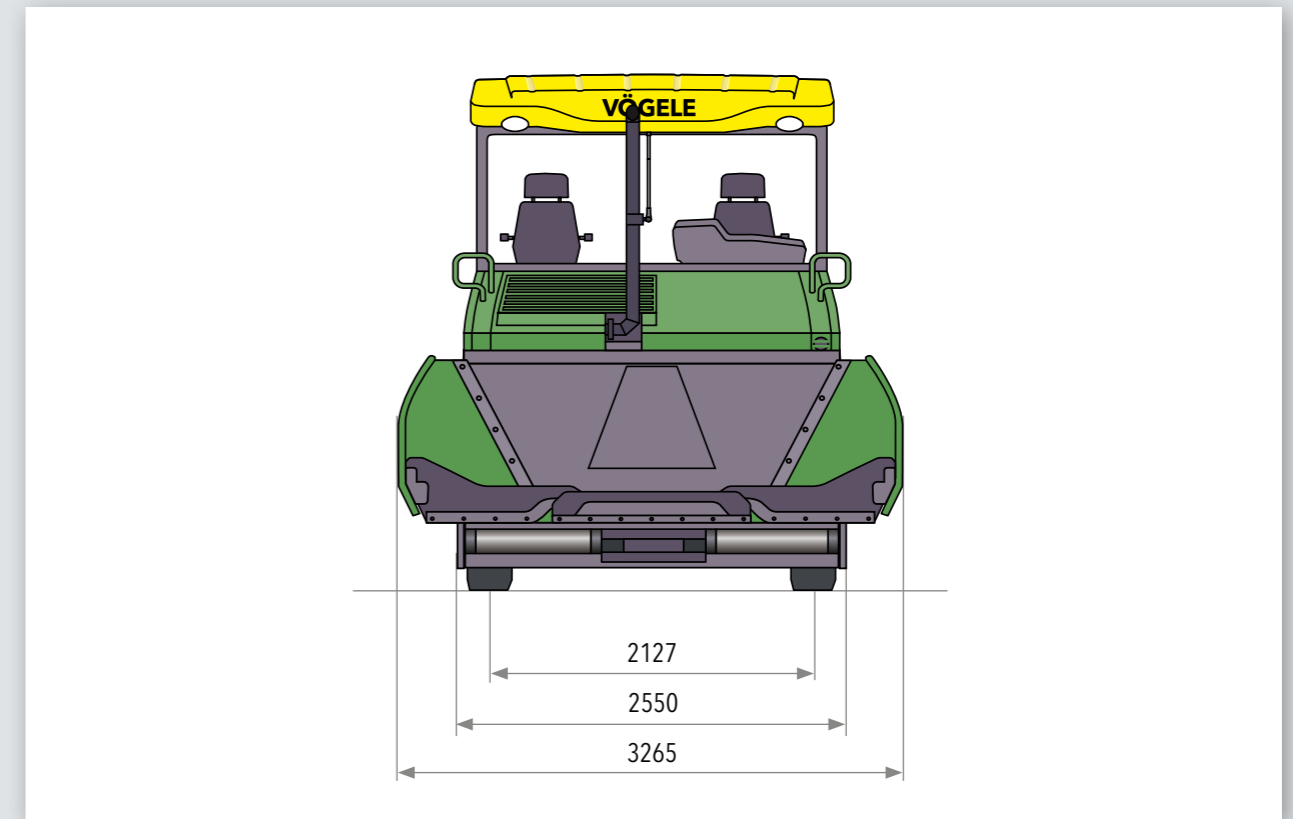
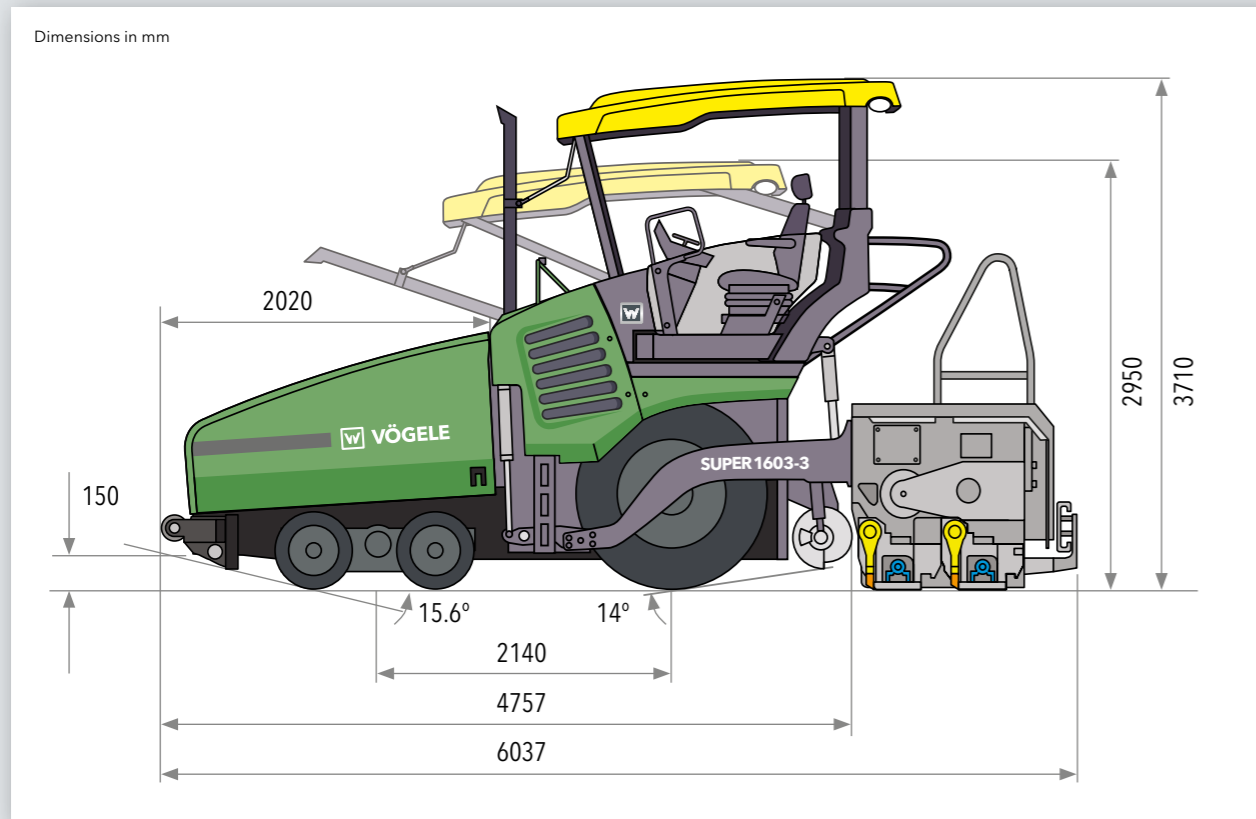

Power unit	
Engine	4-cylinder diesel engine, liquid-cooled
Manufacturer	Cummins
Type	QSB4.5 C155
Output	
Nominal	116kW at 2,000rpm (according to DIN)
ECO mode	106kW at 1,700rpm
Exhaust emissions standard	EU Stage 3a, US EPA Tier 3
Fuel tank	215 litres

Undercarriage	
Front wheels	4, mounted on bogies (oscillating axle)
Tyre equipment	elastic solid rubber tyres
Tyre size	540/300 - 390mm
Rear wheels	2, pneumatic tyres, tubeless
Tyre size	14.00 R 25
Drive	separate hydraulic drive provided for each wheel
Standard	2 rear wheels (6x2)
Option	2 rear wheels and 2 front wheels (6x4) 2 rear wheels and 4 front wheels (6x6)
Speeds	
Paving	up to 18m/min., infinitely variable
Travel	up to 20km/h, infinitely variable
Outside turning radius	minimum 3.5m (with Pivot Steer)
Material hopper	
Hopper capacity	13t
Width	3,265mm
Feed height	594mm (bottom of material hopper)
Push-rollers	oscillating
Position	can be displaced forwards by 75mm or 150mm

Conveyors and augers	
Conveyors	2, with replaceable feeder bars, conveyor movement reversible for a short time
Drive	separate hydraulic drive provided for each conveyor
Speed	up to 33m/min., infinitely variable (manual or automatic)
Augers	2, with replaceable auger blades, auger rotation reversible
Diameter	400mm
Drive	separate hydraulic drive provided for each auger
Speed	up to 84 rpm, infinitely variable (manual or automatic)
Height	infinitely variable by 15cm, hydraulic, lowest position 10cm above the ground
Lubrication	automatic centralized lubrication system with electrically driven grease pump

Screed options		
AB 480	basic width	2.55m
	infinitely variable range	2.55m to 4.8m
	maximum width	6.3m
AB 500	basic width	2.55m
	infinitely variable range	2.55m to 5m
	maximum width	7m
Screed version	TV	
Layer thickness	up to 30cm	
Screed heating	electric by heating rods	
Power supply	three-phase A.C. generator	
Dimensions (transport) and weight		
Length	tractor unit with screed	
AB 480/500 TV	6.04m	
Weight	tractor unit with screed	
AB 500 TV	17.5t	

Key: **AB** = Extending Screed **TV** = with tamper and vibrators

Subject to technical modification.