

All the facts at a glance

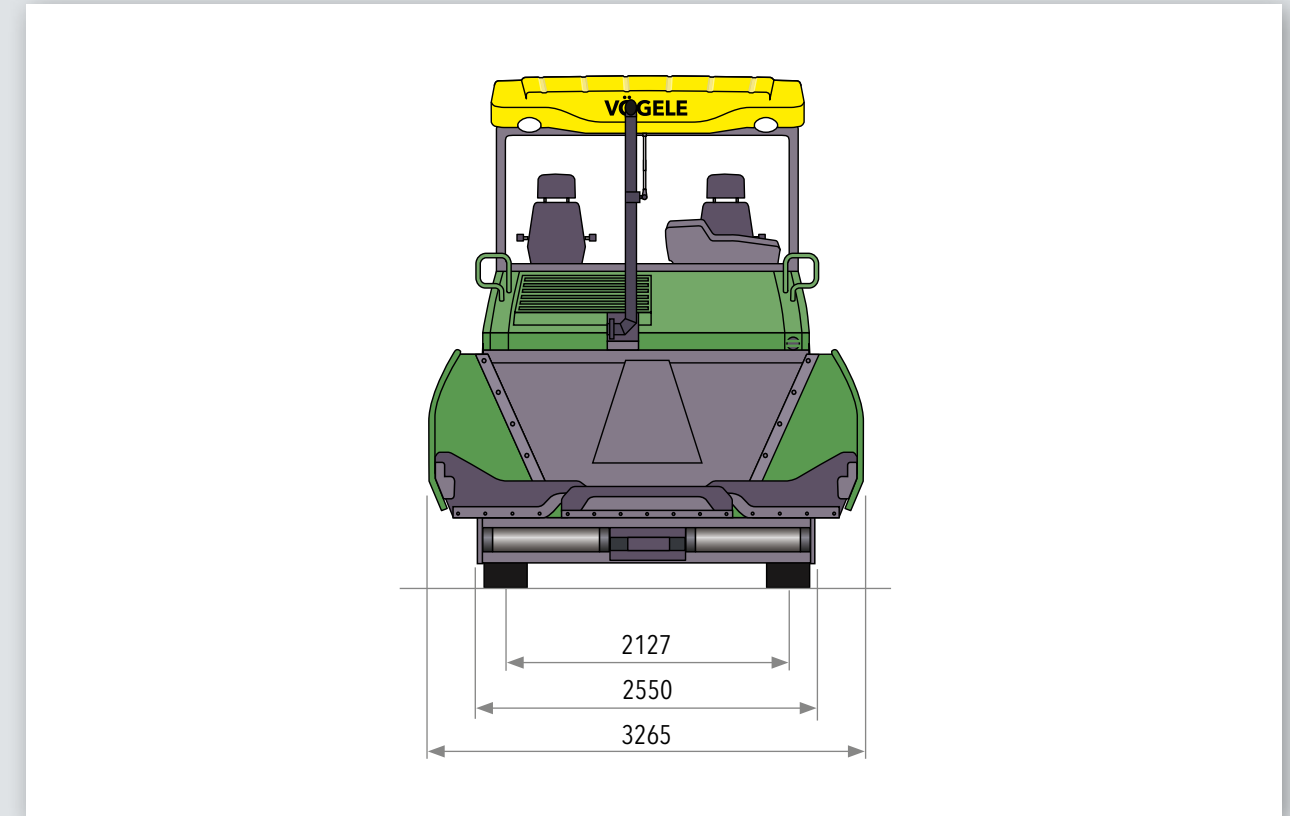
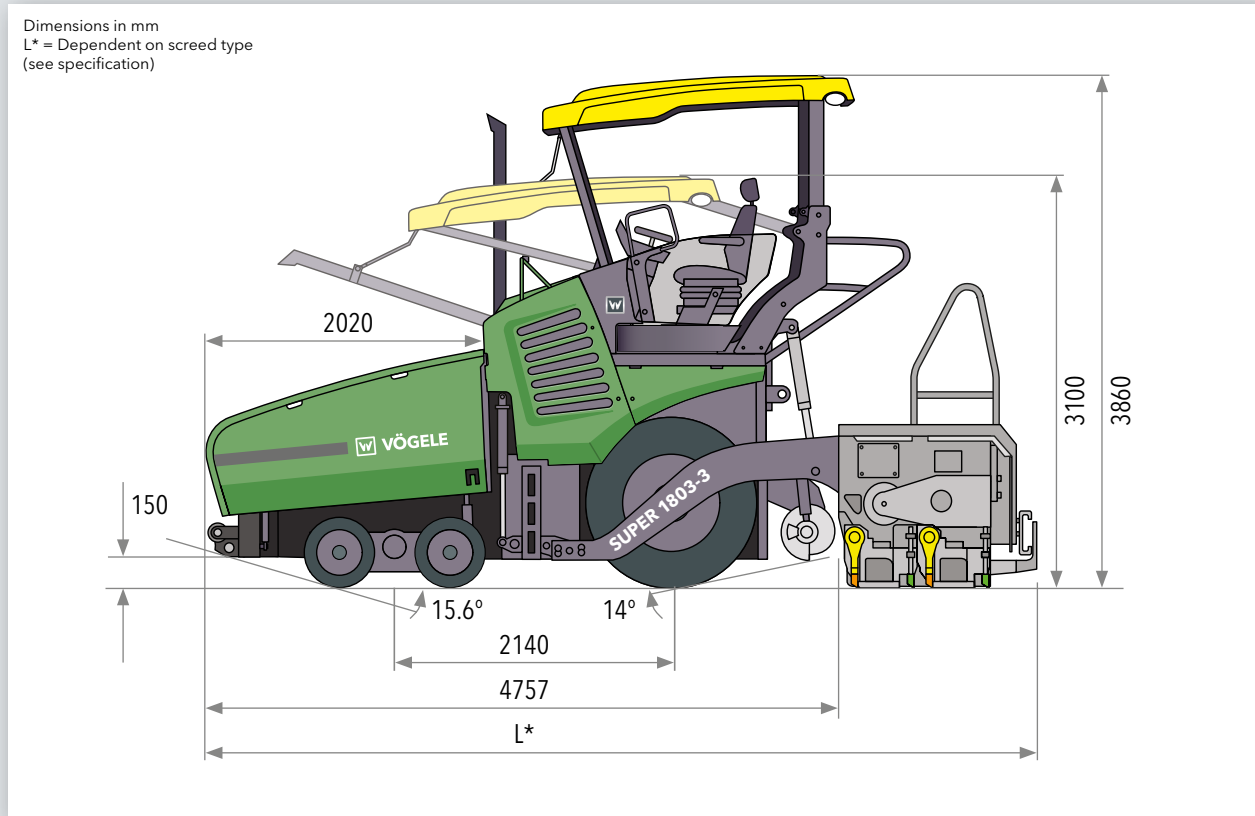

Power unit	
Engine	6-cylinder diesel engine, liquid-cooled
Manufacturer	Cummins
Type	QSB6.7-C170
Output	
Nominal	127kW at 2,000rpm (according to DIN)
ECO mode	116kW at 1,700rpm
Exhaust emissions standard	EU Stage 3a, US EPA Tier 3
Fuel tank	220 litres

Undercarriage	
Front wheels	4, mounted on bogies (oscillating axle)
Tyre equipment	solid tyres
Tyre size	540/300 - 390mm
Rear wheels	2, pneumatic tyres, tubeless
Tyre size	14.00 R 25
Drive	separate hydraulic drive provided for each wheel
Standard	2 rear wheels and 2 front wheels powered
Option	2 rear wheels and 4 front wheels powered (all-wheel drive)
Speeds	
Paving	up to 18m/min., infinitely variable
Travel	up to 20km/h, infinitely variable
Outside Turning Radius	3.5m (with Pivot Steer)
Material hopper	
Hopper capacity	13t
Width	3,265mm
Feed height	594mm (bottom of material hopper)
Push-rollers	oscillating
Position	can be adjusted lengthwise by 75mm or 150mm

Conveyors and augers	
Conveyors	2, with replaceable feeder bars, conveyor movement reversible for a short time
Drive	separate hydraulic drive provided for each conveyor
Speed	up to 33m/min., infinitely variable (manual or automatic)
Augers	2, with replaceable auger blades, auger rotation reversible
Diameter	400mm
Drive	separate hydraulic drive provided for each auger
Speed	up to 84rpm, infinitely variable (manual or automatic)
Height	infinitely variable by 15cm, hydraulic, lowest position 10cm above the ground
Lubrication	centralized lubrication system with electrically driven grease pump

Screed options		
AB 500	basic width	2.55m
	infinitely variable range	2.55m to 5m
	maximum width (TV/TP1)	8m
AB 600	basic width	3m
	infinitely variable range	3m to 6m
	maximum width (TV)	8m
Screed Versions	TV, TP1 (AB 500)	
Layer Thickness	up to 30cm	
Screed Heating	electric by heating rods	
Power Supply	three-phase A.C. generator	
Dimensions (transport) and weights		
Length	tractor unit and screed	
AB 500/AB 600	TV	6m
AB 500	TP1	6.1m
Weights	tractor unit and screed	
AB 500 TV	pave widths up to 5m	17.8t
	pave widths up to 8m	20.3t

Key: AB = Extending Screed TV = with tamper and vibrators TP1 = with tamper and 1 pressure bar

Subject to technical modification.