

All the facts at a glance

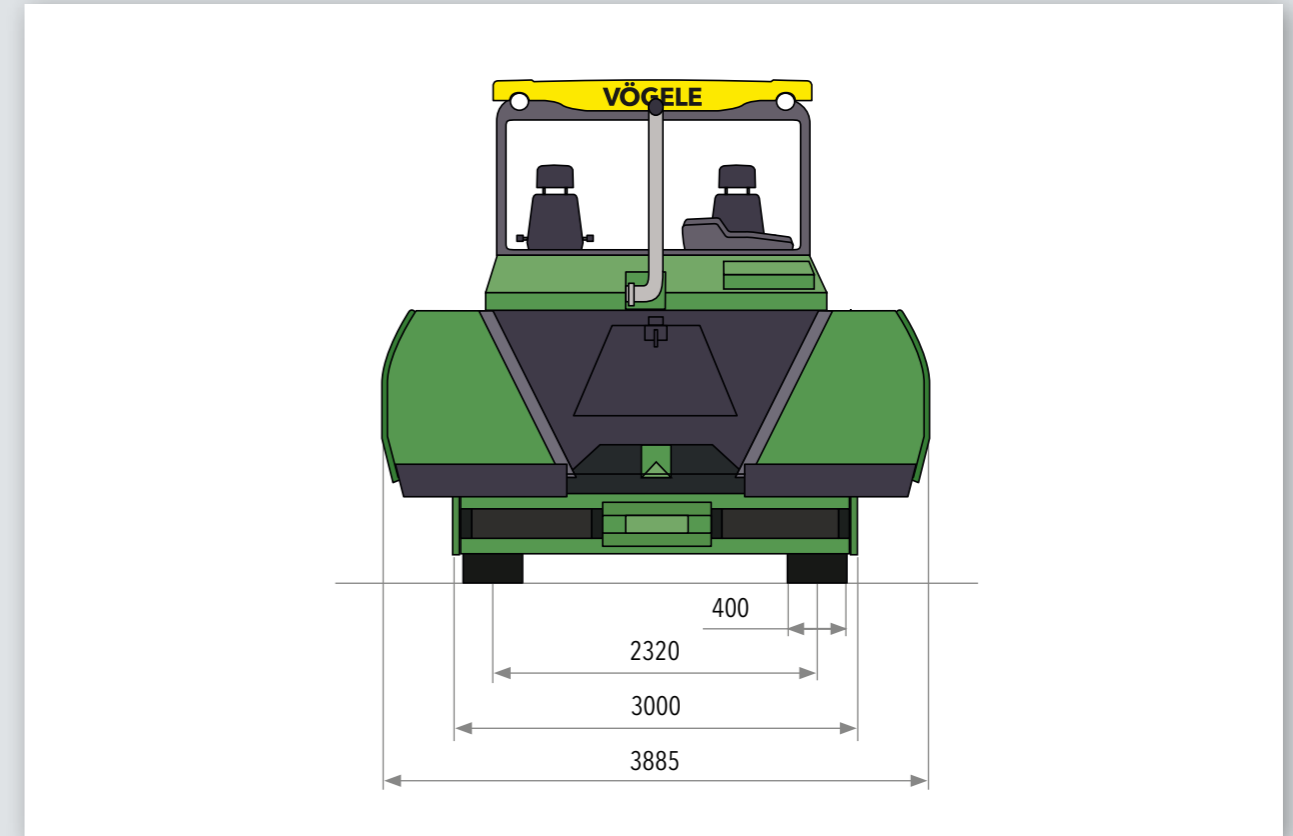
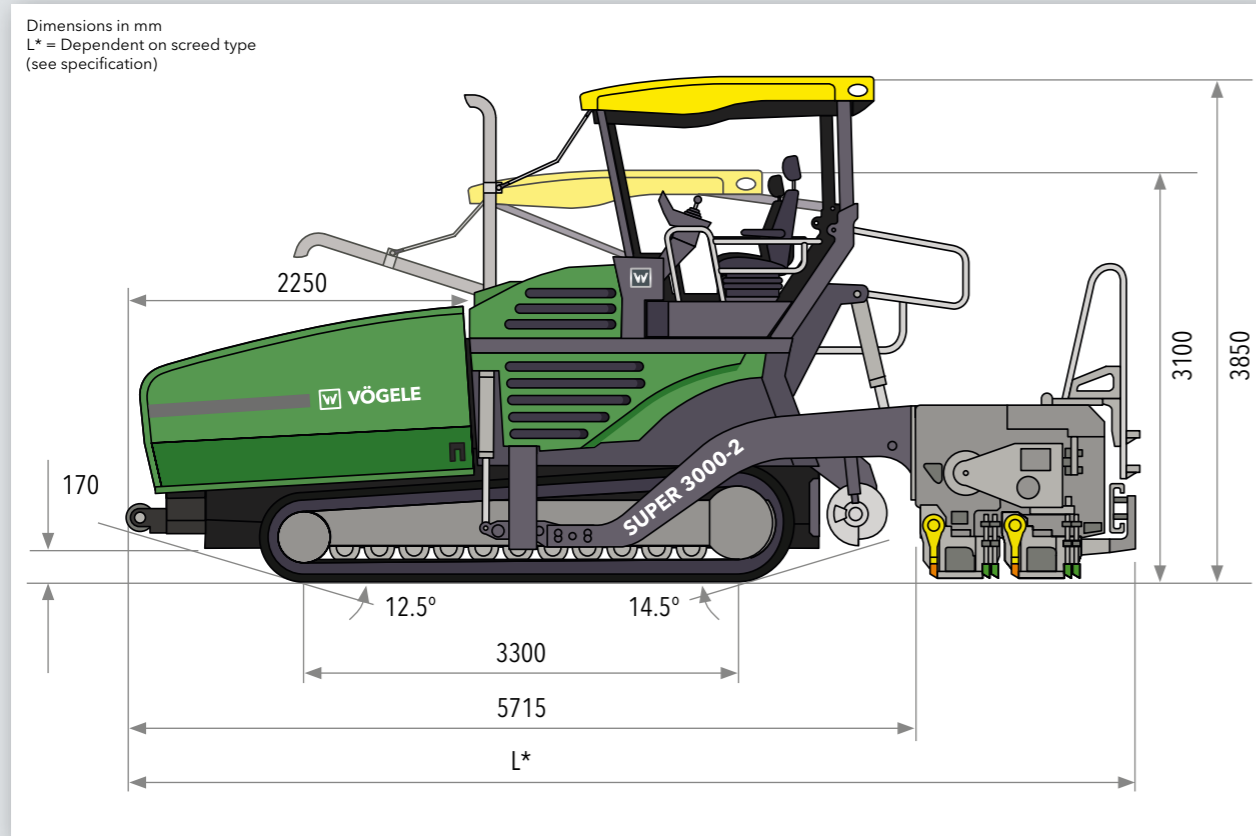

Power unit	
Engine	6-cylinder diesel engine, liquid-cooled
Manufacturer	Deutz
Type	TCD 2015 V06 4V
Output	
Nominal	300kW at 1,800rpm (according to DIN)
ECO mode	292kW at 1,500rpm
Exhaust emissions standard	EU Stage 3a, US EPA Tier 3
Fuel tank	600 litres

Undercarriage	
Crawler tracks	provided with rubber pads
Ground contact	3,300mm x 400mm
Suspension	rigid
Track tension adjuster	elastomer
Track roller lubrication	lifetime
Traction drive	hydraulic, separate drive and electronic control provided for each crawler track
Speeds	
Paving	up to 24m/min., infinitely variable
Travel	up to 4.5km/h, infinitely variable
Steering	by alteration of track running speeds
Material hopper	
Hopper capacity	17.5t
Width	3,885mm
Feed height	620mm (centre of material hopper)
Push-rollers	oscillating
Position	can be displaced forwards by 100mm

Conveyors and augers	
Conveyors	2, with replaceable feeder bars, conveyor movement reversible for a short time
Drive	separate hydraulic drive provided for each conveyor
Speed	up to 43m/min., infinitely variable (manual or automatic)
Augers	2, with replaceable auger blades
Diameter	420mm
Drive	hydraulic, separate drive provided for each auger
Speed	up to 93rpm, infinitely variable
Height	infinitely variable by 20cm, hydraulic
Lubrication	centralized lubrication system with electrically driven grease pump

Screed options		
AB 600	basic width	3m
	infinitely variable range	3m to 6m
	maximum width (TV/TP1/TP2)	9.5m
SB 300	basic width	3m
	maximum width (TV)	16m
Screed versions	TV, TP1, TP2, TP2 Plus (AB 600), TVP2 (SB 300)	
Layer thickness	up to 50cm (SB 300)	
Screed heating	electric by heating rods	
Power supply	three-phase A.C. generator	
Dimensions (transport) and weights		
Length	tractor unit with screed	
AB 600	TV	7m
	TP1/TP2/TP2 Plus	7.1m
SB 300	TV/TP1/TP2/TVP2	6.9m
Weights	tractor unit with screed	
AB 600 TV	pave widths up to 6m	28.7t
	pave widths up to 9.5m	32.6t

Key: AB = Extending Screed SB = Fixed-Width Screed TV = with tamper and vibrators TP1 = with tamper and 1 pressure bar TP2 = with tamper and 2 pressure bars TVP2 = with tamper, vibrators and 2 pressure bars TP2 Plus = with special tamper, 2 pressure bars and additional weights

Subject to technical modification.