

TECHNICAL DATA

COLD PLANER

BM 2000/60-2, BM 2200/60-2

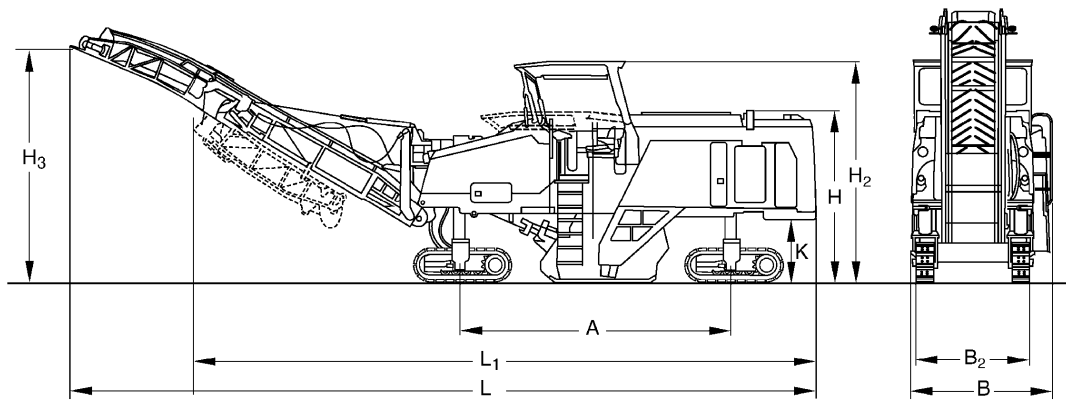



Dimensions in mm

	A	B	B2	H	H2	H3	K	L	L1
BM 2000/60-2	4720	2500	1870	2960	3990	4500	1120	14900	12000
BM 2200/60-2	4720	2500	1870	2960	3990	4500	1120	14900	12000

Shipping dimensions in m3

BM 2000/60-2	110,260
BM 2200/60-2	110,260

Technical Data

BOMAG BM 2000/60-2

BOMAG BM 2200/60-2

Millig drum

Milling width	mm	2.000	2.200
Milling depth	mm	0- 320	0- 320
Milling line distance	mm	15	15
Cutting circle diameter	mm	1.070	1.070
Number of cutting teeth		168	168
Output per cutting tooth	kW	2,62	2,62
Speed	1/min	108	108

Drive

Engine manufacturer		Deutz	Deutz
Type		TCD 2015 V08	TCD 2015 V08
Emission stage		Stage IIIa / TIER3	Stage IIIa / TIER3
Cooling		Liquid	Liquid
Number of cylinders		8	8
Performance ISO 3046	kW	440,0	440,0
Performance ISO 3046	hp	600,0	600,0
Speed	min-1	1.900	1.900
Fuel		Diesel	Diesel
Electric equipment	V	24	24

Weights

Grossweight	kg	32.500	33.500
Operating weight CECE	kg	30.300	31.300
Basic weight	kg	28.100	29.100

Driving Characteristics

Track radius, inner	mm	2.100	2.100
Speed (1)	km/h	5,0	5,0
Working speed, max.	m/min	0- 40	0- 40

Chassis

Type of chassis		crawler	crawler
Width	mm	300	300
Height	mm	640	640
Length	mm	1.700	1.700

Capacities

Fuel	l	1.200,0	1.200,0
Water	l	3.500,0	3.500,0
Hydraulic	l	230,0	230,0

Loading system

Width of gathering belt	mm	800	800
Length of gathering belt	mm	2.400	2.400
Width of loader conveyor belt	mm	800	800
Length of loader conveyor belt	mm	7.600	7.600

Dimensions

Transport dimensions, belt lowered, leng	mm	14.900	14.900
Transport dimensions, belt lowered, widt	mm	2.500	2.500
Transport dimensions, belt lowered, heig	mm	2.960	2.960
Transport dimensions, belt folded, lengt	mm	12.000	12.000

Technical modifications reserved. Machines may be shown with options.

Standard Equipment

- Four-track steering
front or/and rear, crabwalk
- Automatic max. load control
- Differential lock
- Automatic milling depth control MOBA
- 2 MOBA Displays
- Slope control with slope sensor
- Hydraulically foldable conveyor belt
- Display of RPM
- Display of engine oil pressure and
temperature
- Display of operating hours
- Display of diesel level
- Display of hydraulic oil temperature
- Display of hyd. system pressures
- ground control panels
- Sound insulated engine hood
- 10 removable headlights
- Adjustable water spraying system
- tool box for servicing and maintenance
- Back-up warning signal
- Rotary beacon

Optional Equipment

- Hydraulically foldable canopy
- Hydraulically pump for water re-filling
- High pressure cleaner
- Levelling with ultra sonic sensor
- Electrical diesel pump for fuel refilling
- compressed air system
- Diesel filling pump
- Conveyor belt floating position
- Panorama mirror
- Milling box 2000
- Milling box 2200
- Milling-Drum 2000-1070-6x2
- Milling-Drum 2000-1070-15
- Milling-Drum 2200-1070-15
- Milling-Drum 2000-1070-18
- Conveyor unit
- Dust reduction system
- EAC certificate (group3)
- Environmental protection certificate for
China

