



# TECHNICAL DATA

MOUNTED SPREADER

BS 10, BS 16



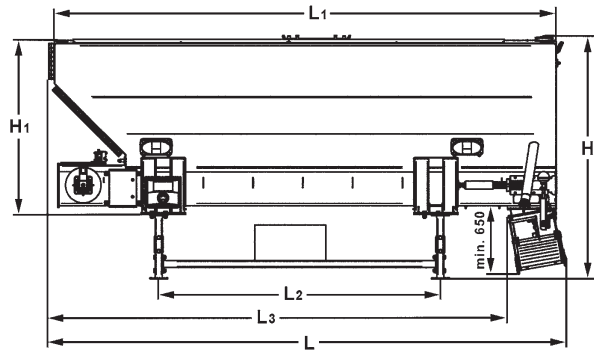
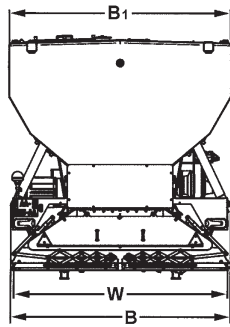

**Standard equipment**

- Speed-dependent dosage
- Radar sensor for speed detection
- 2 LED working head lights at the rear
- Compressed air filling from left and right
- Variable working width

**Optional equipment**

- Weighing plate for dosage control
- Electronic weighing device
- Camera system at the rear
- Device for Big Bag or silo filling from above
- Pneumatic compressor 1,200 l – 8 bar, for cleaning
- Pneumatic compressor 8,000 l – 2 bar, for filling
- High-pressure cleaner (BS 16)
- Water tank for high-pressure cleaner (BS 16)

**Dimensions in mm**

**BS 10**  
**BS 16**

	B	B1	H	H1	L	L1	L2	L3	W
BS 10	2480	2500	2740	2015	4000	3810	1230	3335	2400
BS 16	2480	2500	2740	2015	5830	5650	3070	5165	2400

**Technical data**

Type .....	
Capacity .....	m <sup>3</sup>
Output* .....	kg/m <sup>2</sup>
Working width.....	m
Weight (empty) .....	kg
Permissible total weight.....	kg

**BOMAG  
BS 10**

**BOMAG  
BS 16**

	BOMAG BS 10	BOMAG BS 16
Mounted spreader	10	16
Output	5 to 50	5 to 50
Working width	1 / 1.5 / 2 / 2.4	1 / 1.5 / 2 / 2.4
Weight (empty)	3,910	4,860
Permissible total weight	13,910	20,860

\* Crawling gear required

**Requirements for hydraulic pump of carrier vehicle**

Pressure .....	bar	300	300
Quantity.....	l/min	80	80
Control.....		Load-Sensing	Load-Sensing

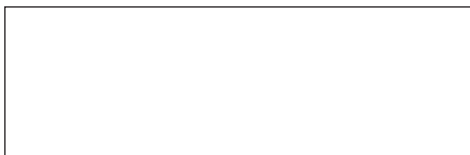

PRE 910 92 010

270120 Sa

**BOMAG**  
Hellerwald  
D-56154 Boppard  
Postfach 5162  
D-56149 Boppard  
Tel. (0)6742 - 1000  
Fax (0)6742 - 3090

