

TECHNICAL DATA

TOWED SPREADER

BS 10, BS 16

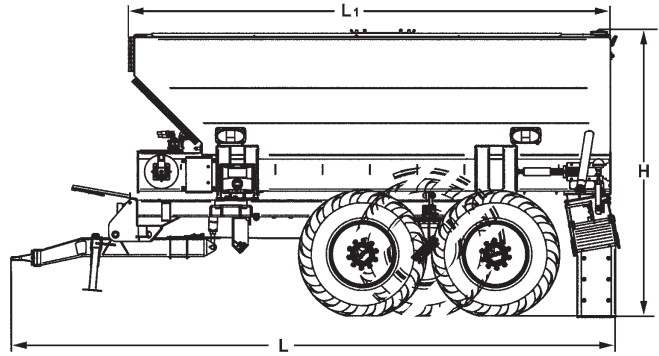

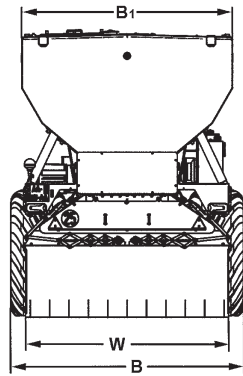

Standard equipment

- Tyres with Ø 1,650 mm and width 650 mm (BS 10)
- Tyres with Ø 1,450 mm and width 650 mm (BS 16)
- Spring-loaded bogie axle (oscillating unit) (BS 16)
- Spring-loaded steering rod (BS 16)
- Hydraulically-controlled brake
- LED rear and brake lights
- Speed-dependent dosage
- Radar sensor for speed detection
- 2 LED working head lights at the rear
- Compressed air filling from left and right
- Variable working width
- Towing coupling
Rockinger Ø 40 mm

Dimensions in mm

	B	B1	H	L	L1	W
BS 10	2760	2500	3320	5640	3810	2400
BS 16	2760	2500	3400	7220	5650	2400

Technical data

	BOMAG BS 10	BOMAG BS 16
Type	Towed spreader bottom	Towed spreader bottom
Attachment		
Capacity	10 m ³	16
Output*	5 to 50 kg/m ²	5 to 50
Working width	1 / 1.5 / 2 / 2.4 m	1 / 1.5 / 2 / 2.4
Weight (empty)	5,960 kg	8,800
Permissible total weight	15,960 kg	24,880
Nose weight – tank empty	620 kg	1,100
Nose weight – tank full	1,421 kg	3,570
Permissible transport speed	25 km/h	25
Tyre type	650/60 R34.5	650/65 R26.5
Number of axles	1	2
Drive speed of propshaft	540 min ⁻¹	540

* Crawling gear required

Optional equipment

- Weighing plate for dosage control
- Electronic weighing device
- Towing coupling K80 (Scharmüller)
- Towing coupling
Rockinger Ø 50 mm
- Pneumatic brake system
- Device for Big Bag or silo filling from above
- Pneumatic compressor
1,200 l – 8 bar, for cleaning
- Pneumatic compressor
8,000 l – 2 bar, for filling
- High-pressure cleaner (BS 16)
- Water tank for high-pressure cleaner (BS 16)

