

TECHNICAL DATA

REFUSE COMPACTOR

BC 772 RS-2

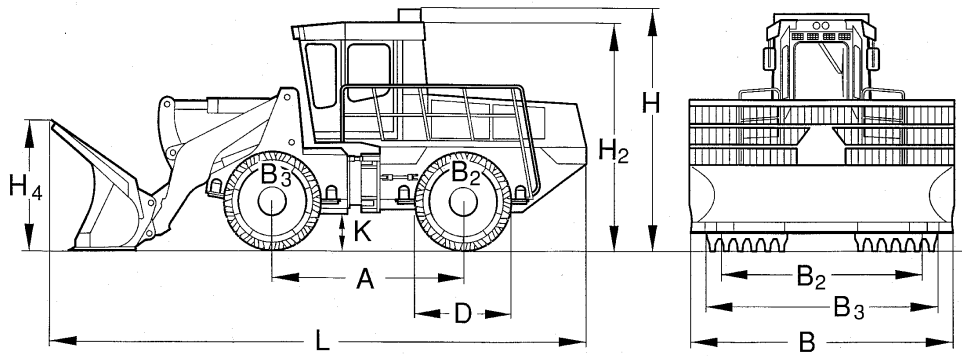



Dimensions in mm

	A	B	B2	B3	D	H	H2	H4	K	L
BC 772 RS-2	3875	3800	3550	3775	1660	4120	3820	1800	600	9275

Shipping dimensions in m3

BC 772 RS-2

134,636

Technical Data

BOMAG BC 772 RS-2

Weights

Grossweight	kg	37.900
Operating weight CECE	kg	37.300
Axle load, front CECE	kg	20.800
Axle load, rear CECE	kg	16.500

Driving Characteristics

Speed (1), forward	km/h	0- 4,0
Speed (1), reverse	km/h	0- 4,0
Speed (2), forward	km/h	0- 7,5
Speed (2), reverse	km/h	0- 7,5
Speed (3), forward	km/h	0- 12,0
Speed (3), reverse	km/h	0- 12,0
Max. gradeability (dep. on soil con.)	%	75
Max. pushing force	kN	403

Drive

Engine manufacturer		Deutz
Type		TCD 2015 V06
Emission stage		Stage IIIa / TIER3
Cooling		water
Number of cylinders		6
Performance ISO 9249	kW	330,0
Performance SAE J 1349	hp	442,0
Speed	min-1	2.100
Travel system		hydrost.
Operating voltage	V	24

Compaction Wheels

Width, front	mm	1.350
Width, rear	mm	1.125
Outer diameter (front)	mm	1.660
Outer diameter (rear)	mm	1.660
Number of teeth/cutters, front		60
Number of teeth/cutters, rear		50
Compaction coverage per side	mm	1.350

Brakes

Service brake		hydrost.
Parking brake		hydromec.

Steering

Steering system		oscil.artic.
Steering method		hydraulic
Steering angle +/-	grad	30
Oscillating angle +/-	grad	15
Track radius, inner	mm	3.750

Capacities

Fuel	l	750,0
Engine oil	l	36,0
Hydraulic oil	l	350,0

Technical modifications reserved. Machines may be shown with options.

Standard Equipment

Optional Equipment

- Premium compaction wheels with highly wear resistant teeth
- Polygonal compaction wheels, teeth with replaceable caps
- Pre start cabin heating
- Fire extinguisher
- Special painting
- Environmentally compliant hydraulic oil
- Protective ventilation system (Pre-installation)
- Lockable hood lock (anti-theft protection)
- Tool kit
- Automatic heating - air conditioning
- Tachograph
- Bucket tooth system
- TELEMATIC POWER

